



2010 *Private Use* Application Guide • Volume 11 • Issue 1 • 1-11-10



RAMPVAN[®]

Rampvan® Features

Built on the 2007-2010 Toyota Sienna chassis, the BraunAbility Rampvan® is the culmination of over thirty-five years experience in building personal mobility products. Style, performance, convenience and safety have been aesthetically blended to achieve a new level of refinement in a wheelchair-accessible minivan.

One glance at the sleek lines and custom ground effects tells you it's truly like no other minivan on the road. But the touch of a button on the OEM keychain quickly reveals what makes the Rampvan® special.

On a power conversion, the sliding door opens, the rear suspension lowers and the ramp unfolds to reveal a spacious interior designed to meet the needs of wheelchair and scooter users down to the last detail. The lowered floor allows you to ride at a comfortable height in your chair, offering ample head clearance. A manual conversion is available.

Removable seating enables you to drive or ride in the front or middle passenger position. Interior control switches are placed throughout the vehicle, putting you in complete command of your mobility. A driver-side wheelchair securement system can be installed by a BraunAbility Dealer. All of these thoughtful features result in an accessible and stylish vehicle like no other; the Rampvan® by BraunAbility.

At the heart of the Rampvan® conversion lies the acclaimed Toyota Sienna, consistently rated as a favorite among minivan owners. Through an exclusive partnership, BraunAbility and Toyota have worked hand-in-hand to create an accessible vehicle that offers many advantages: superior carrying capacity, maximum headroom, lowered-floor width, and ample ground clearance.

Safety has always been a top priority at BraunAbility. The Rampvan® has been crash tested and certified to meet or exceed all applicable requirements of the Federal Motor Vehicle Safety Standards (FMVSS) and is backed by our 3 year/36,000 mile limited and 5 year/unlimited mile rust-through metal protection on every vehicle that leaves the factory. Add to this the original Toyota warranty for unconverted parts and a nationwide dealer network, and you can rest assured BraunAbility will be there to support you no matter where your travels take you.



Rampvan®

2007-2010 Toyota Sienna Chassis ▶

(Foldout Ramp shown - Infloor Ramp available)

See Chassis Information page for Chassis Requirements



Lowered Floor

Up to 11" lower than conventional minivans, the floor is lowered from the firewall to the rear axle and provides a choice of three wheelchair securement positions.

Automatic Door (Power Conversion)

The OEM Toyota power door operator opens the sliding door at the touch of a button. The vehicle **must be** equipped with the OEM Toyota power door operator for a power conversion. A manual conversion is also available.



Automatic Ramp (Power Conversion)

The lightweight ramp is offered in both Infloor and Foldout versions, and offers unparalleled ease of access for wheelchair and scooter users. A manual foldout conversion is also available.



Automatic Kneeling Rear Suspension (Power Conversion)

The Rampvan® features a kneeling system to make boarding even easier. An actuator lowers the rear suspension while the door opens, which reduces the slope of the automatic ramp.

Custom Ground Effects

Adds stylish lines and enhances smooth OEM appearance.



Integrated Keyfob Remote (Power Conversion) ▶

The OEM Toyota keychain remote controls all the accessible features.



OEM-Style Switches (Power Conversion)

Controls all the accessible features from multiple positions.



Removable Seating ▶

Both the driver and passenger seat can easily be removed for those who wish to ride up front or drive.



Wheelchair/Occupant Securement System

One belt system is included for use with the floor-mounted tracks.



Rampvan® Dimensions

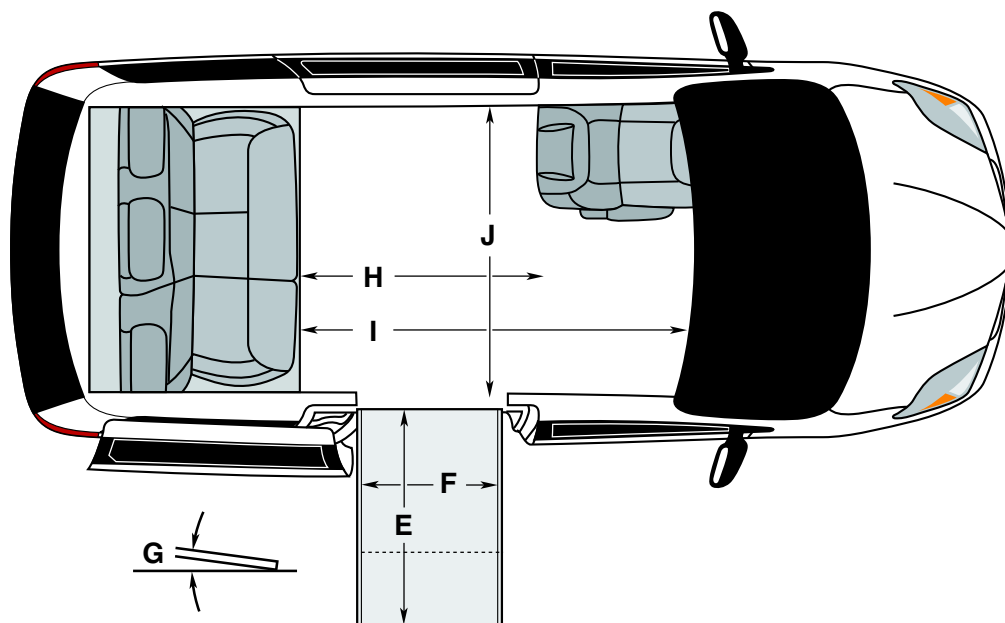
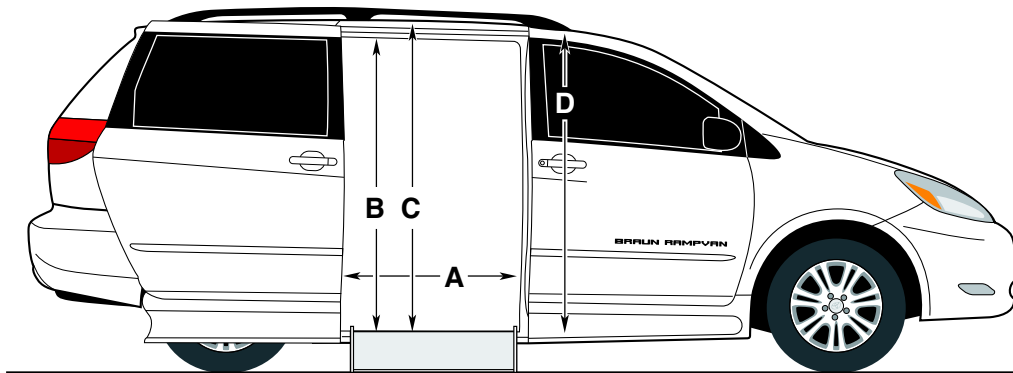

* Deduct 2-3/4" off of Interior Height for Applications with Overhead DVD/Rail System

** Deduct 3" off of Interior Height for Applications with Moon Roof

All dimensions are for reference only.

		Foldout Ramp	InFloor Ramp
Door Opening Usable Width (Slide Door)	A	31-1/4"	32-1/4"
Door Opening Usable Height (Slide Door)	B	54-1/4"	53-3/8"
Interior Height at Center of Van*	C	59-1/4"	58-1/4"
Interior Height at Driver and Passenger Position**	D	57-1/4"	56-3/4"
Ramp Length	E	52"	48"
Ramp Width (Usable Clear Opening)	F	29-1/4"	30"
Ramp Angle (with Vehicle Kneeled)	G	9.1°	10.2°
Interior Floor Length (Behind Front Seats)	H	50"	50"
Overall Interior Floor Length (Flat Area)	I	83-1/2"	83"
Interior Width at B Pillars	J	62-1/4"	61-1/2"

Due to manufacturing tolerances both with the OEM vehicle and the conversion components, all dimensions may vary slightly from those shown.